

## APPLICATION

The Uni-P Renegade 125X dehumidifier is the latest addition to the Uni-P water damage and restoration product line. This unit features the new cutting-edge Super Low Grain Refrigerated – SLGR. technology.

This advance dehumidification technology allows the Uni-P Renegade 125X dehumidifier, to remove at least 125 pints of water per day at AHAM and 100L at 30, 80% RH conditions.

The Uni-P Renegade 125X dehumidifier SLGR technology ensures this unit is able to remain highly efficient at high-temperature conditions of even above 130 degrees Fahrenheit.

The Uni-P Renegade 125X dehumidifier remains energy efficient while operation using up only 8.1. amps, 110 VAC. Should always be plugged into a grounded outlet of 15 amps circuit.

The Uni-P Renegade 125X dehumidifier features a high-impact roto-molded housing that protects the unit air while being moves, the dehumidifier should always remain upright while operation or when been moved.



## PERFORMANCE

- **Low humidity dehumidification** - The Uni-P Renegade 125X dehumidifier ability to keep lowering the humidity levels even at below 30% relative humidity is what sets this unit apart from all dehumidifiers in the market.
- **Low noise levels** - This unit is able to deliver outstanding results in low humidity and extremely high temperature while producing sound levels of below 60 DBA. This will ensure your space remains comfort with no vibration or buzzing sounds from your dehumidifier.
- **Air filtration** - The Uni-P Renegade 125X dehumidifier is fitted with prefilter and MERV – 8 filter, that are able to trap even the smallest mold spore, allergens, and dust particles. This improves the quality of your indoor air and reducing respiratory problems and allergies.

**Note:** to achieve the desired dehumidification results with The Uni-P Renegade 125X dehumidifier, space must be free of water intrusion or excessive fresh outdoor air infiltration. All water intrusion and air infiltration problems should be fixed before installation.

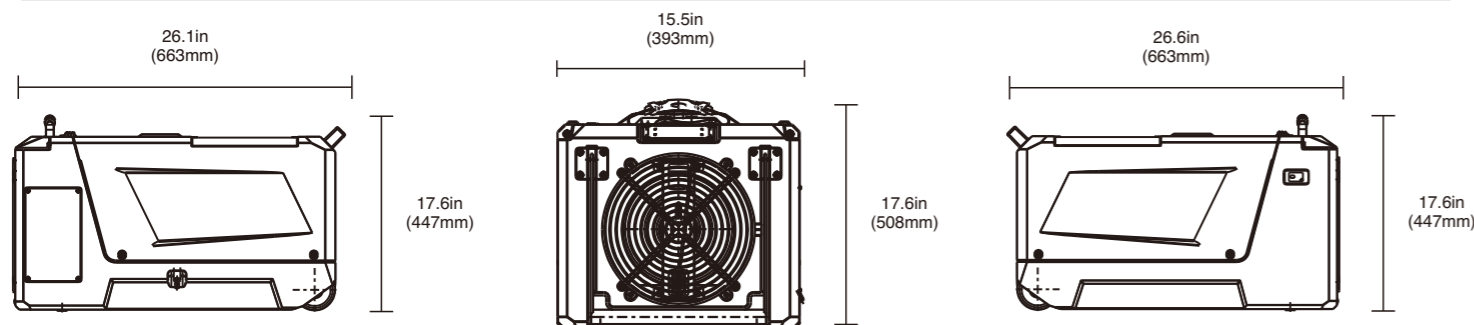

# UNI-RENEGADE 1250X

## Commercial Dehumidifier

### FEATURES

- ✓ CE, ETL
- ✓ Easy clean – shell can be opened to access all components
- ✓ Easy to store wires and hoses
- ✓ Ducting Options
- ✓ Built-in Condensate Pump
- ✓ Environmental R410A Refrigerant
- ✓ Sturdy handle-Large Diameter
- ✓ Microchannel Cold a Heat Exchanger
- ✓ Superior Stacking
- ✓ Rotational Molded Body
- ✓ Water-Full Protection
- ✓ Rotary Compressor
- ✓ Automatic Humidistat Control
- ✓ Quick connection to Cable/Hose
- ✓ Memory Starting
- ✓ MERV-8 Filter
- ✓ Low Temperature

## SPECIFICATIONS

**SLGR Microchannel**  
Excellent In Low Humidity and High Temperature

**Power**  
115V/60HZ

**Size For**  
Up to 3000Sq.FT

**Filter**  
MERV-8 Filter

**Air flow**  
300CFM, 510CMH

**Sound Pressure Level**  
<60DBA

**Cord**  
19.6ft (6m)

**Draining**  
Condensate Pump

**Functioning Temperature Range**  
33.8~110°F

**Functioning Humidity Range**  
25~80%

**Capacity 115V(80°F-60%)**  
125 Pints/Day

**Defrosting Control System**  
Automatic Defrosting

**Refrigerant**  
R410a

**COP(115v/60Hz)**  
2.66 L/Kwh (115V/60Hz)

**Dim**  
26.1"(L) x 15.5"(W) x 17.6"(H)

**Weight**  
81.6lbs (38KG)

**Loading quantity**  
20"H: 143Sets; 40": 312 Sets; 40": 360Sets

**Wheel**  
2 Big Wheel